

TO AUTOMATION
POWER CONNECTION

AUTOMATION POWER FEED 120V
AUTOMATION POWER FEED NEUTRAL
AUTOMATION POWER FEED GROUND

MOTOR IN
MOTOR OUT
AUX IN
AUX OUT
LAMP IN
LAMP OUT
EXCITER IN
EXCITER OUT
CHANGE-OVER FEED
CHANGE-OVER CLOSE
CHANGE-OVER OPEN
TURRET CONTROL COMMON
TURRET FLAT
TURRET SCOPE

MANUAL SWITCH
CONNECTION

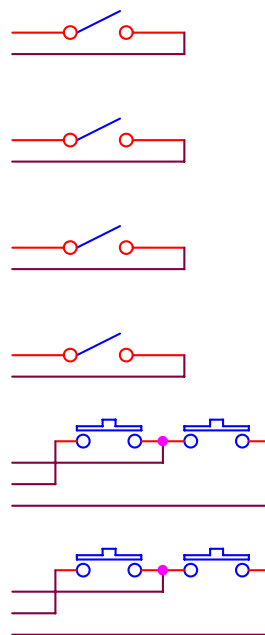

HIGH POWER INTERFACE BOARD (HPIB)
INTERCONNECTS & FUNCTIONS OF TB-2
CONNECTIONS

MOTOR SWITCH LOOP, FEED FROM TB11-15 & 16
ON HPIB TO CONTROL PROJECTOR MOTOR

AUX FUNCTION/SWITCHED OUTLET LOOP,
FEED FROM TB17-5 & 6 ON HPIB

XENON LAMP POWER SUPPLY CONTROL LOOP,
FEED FROM TB13-3 & 4 ON HPIB, LOOP ON
HPIB ALSO INCLUDES LOWER DOOR SWITCH
PLUG/JUMPER.

CONTROL LOOP FOR EXCITER SUPPLY POWER
FEED, FEED FROM SOUND CB, OUTPUT ON HPIB
TB16-4 SWITCHED SOUND

CHANGE-OVER FUNCTION, FEED FROM HPIB
TB11-9, SWITCHED TO OPEN (HPIB TB11-11) AND
CLOSE (HPIB TB11-12) OUTPUTS TO PROJECTOR

CONTROL LOOP FOR TURRET, CONNECTED
FROM HPIB TB11-1, 2, & 3 AS MARKED

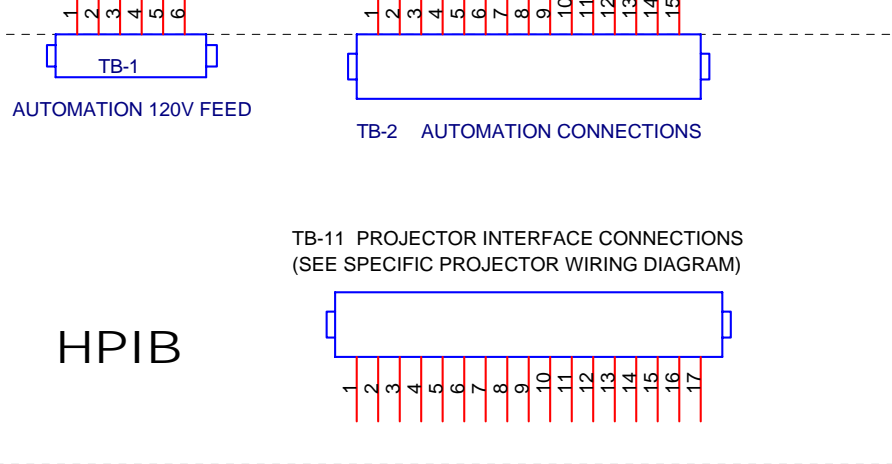

HPIB

BIG SKY INDUSTRIES, ALPHA HJ		
Title HPIB TO AUTOMATION WIRING CONNECTIONS		
Size A	Document Number HPIB TB-2 WIRING	Rev
Date:	Monday, June 12, 2006	Sheet 1 of 1