

**RECTIFIER POWER SUPPLIES**

*A3 series*

**INSTALLATION AND OPERATION MANUAL**

**MAN0100/3**



## **Warnings**

***You should read this manual before attempting any intervention inside the unit.***

***The noncompliance with the instructions given in this manual can lead to serious damage to the unit which in this case will invalidate the warranty.***

***No compensation or indemnity under any kind will be acknowledged for injury or damage due to use or misuse of the product, for poor operation of the appliances connected to IREM product or for immediate or indirect damage caused to the powered equipment.***

***During the warranty period the replacement of defective parts and maintenance procedures will be exclusively carried out at IREM servicing centre.***

***Keep this manual along with the unit.***

***CE declaration is available on request.***

This manual aims to give some operating instructions to the user in order to grant a safe and optimal use of the unit.

Keep this manual along with the unit. You should read it carefully both for installation, starting-up and maintenance procedures.

This manual is composed by the following sections:

- . description  
(product and application fields)
- . rectifier component layout
- . connection and operating information  
(directions for connection, start-up and use of the power supply)
- . technical characteristics  
(technical specifications).

## Table of contents

|  |    |
|--|----|
| GENERAL PURPOSES                         |    |
| <i>Description*</i> .....                | 4  |
| Block diagram .....                      | 5  |
| Characteristics .....                    | 6  |
| RECTIFIER COMPONENT LAYOUT               |    |
| <i>Rectifier component layout*</i> ..... | 7  |
| CONNECTION AND OPERATING INFORMATION     |    |
| Receiving the unit .....                 | 9  |
| Delivery arrangement .....               | 9  |
| Storage .....                            | 9  |
| Package removing and handling .....      | 10 |
| Warnings .....                           | 11 |
| Preliminary checks .....                 | 11 |
| <i>Installation-use*</i> .....           | 12 |
| TROUBLESHOOTING                          |    |
| Possible failures .....                  | 14 |
| Preventive maintenance .....             | 15 |
| Diode replacement instructions .....     | 16 |
| TECHNICAL DATA                           |    |
| G3 technical specifications .....        | 18 |
| Power factor correction .....            | 18 |
| <i>Outline drawing*</i> .....            | 19 |

\* these sections have been modified with respect to the previous issue.

## General purposes

### Description

These high quality rectifier power supplies have been expressly designed to ensure the correct operation and long life of short arc Xenon lamps.

These units, developed to meet the recommendations of Xenon lamp manufacturers, are fitted with special **IREM** transformers with adjustable magnetic shunt for continuous output regulation over the entire operating range.

The new and peculiar design guarantees a low acoustical noise, i.e. less than 55dB(A). The special design, including an auxiliary filter unit, ensures a low ripple with a negligible starting energy. A 230V AC 2A auxiliary outlet provides power to the igniter when the unit is on.

**G3** rectifiers are particularly suitable for:

- standard film projection
- special effects
- theatre applications
- architectural applications
- solar simulations.

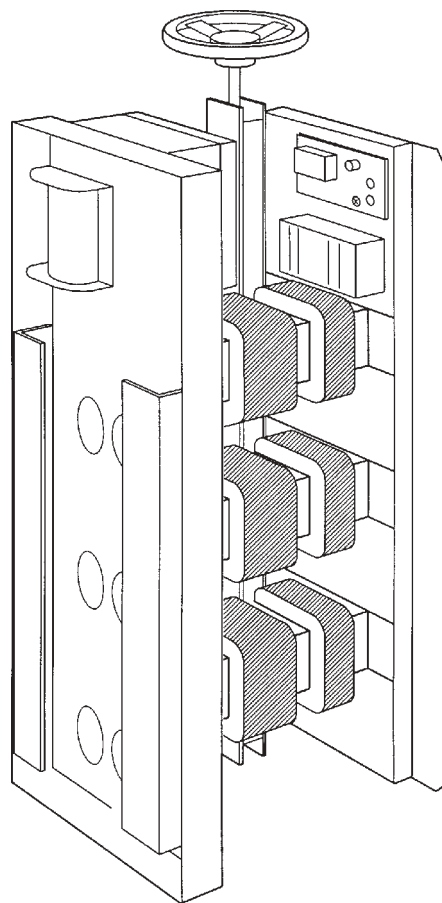

## General purposes

### Block diagram

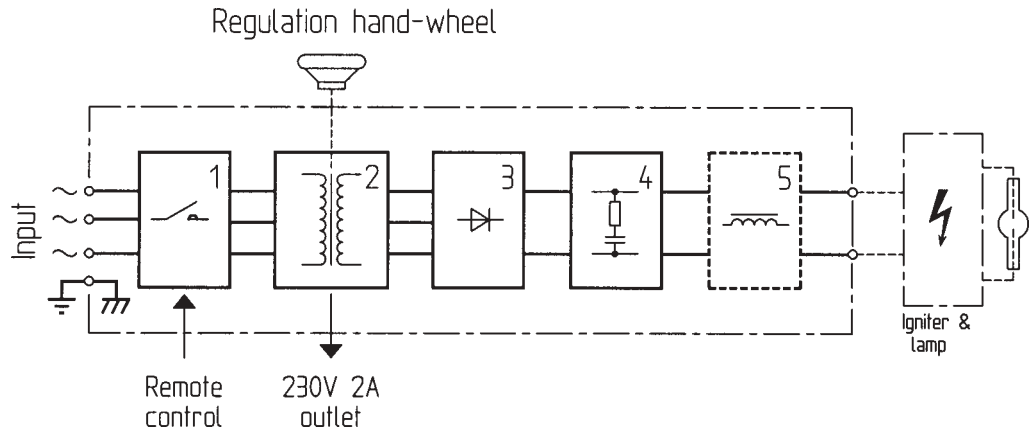

1. Main switch for remote control
2. Special transformer with magnetic shunt
3. Diode bridge rectifier
4. Filter and starting peak suppression circuit
5. Auxiliary filter (AFU) (only if present)

## General purposes

### Characteristics

The **G3** series rectifiers have been expressly designed to power Xenon lamps.

The rectifier consists in a stray-flux transformer with adjustable magnetic shunt, a rectifying unit mounted on a heatsink and levelling filter.

The transformer is formed by three identical single phase transformers "T1, T2, T3" (4) whose primaries are star-connected.

The use of three single phase units "T1, T2, T3" (4) permits to get a balanced magnetic circuit such to reduce the ripple of the rectified output current.

The magnetic shunt "MS" (15), operated by the hand-wheel "H" (12), permits to adjust the output current according to the lamp manufacturers' specifications, even in case of  $\pm 10\%$  input voltage variations.

The transformer secondary windings, provided with central tap, power the diode assembly "D1, D2, D3, D4, D5, D6" (13), centre-tap connected, and protected by "C1, C2, C3, C4, C5, C6" capacitors (14).

An electrolytic capacitor "C7" (3) is connected in parallel across the output, working as a filter to reduce the residual ripple down to 8% peak-to-peak.

The "A1" ignition relay (2) limits the inrush current to the lamp, caused by the discharge of "C7" capacitor (3), and operates a resistor in series to "C7" at the ignition.

The power relay "K1" (5) is remotely operated by a push button connected to the "X1" terminal board.

On the "X1" terminal board, there are the "U V W" input terminals (7), "+ and -" output terminals (11), to be connected to the lamp, and the auxiliary terminals "B, H, A" (8), used to operate the power relay coil "K1" (5).

On G3-150 and G3-180 models, an additional filter unit (AFU) (17) has been added in order to reduce the output current ripple to a value lower than 3%. On demand, AFU filter unit may be assembled on G3-80 and G3-100 models.

Rectifier power supply protection and lamp faulty operation warning:

These devices, mounted in conjunction with AFU filter, aim at:

- . warning the user in case of anomalies that, even if not affecting the film projection, could damage the lamp or shorten its useful life (e.g.: a diode failure).
- . protecting the rectifier against wrong wiring connections during installation
- . protecting the rectifier against severe line disturbances (up to a possible lack of phase)
- . stopping a possible reignition of the rectifier if the failure has not been correctly detected or repaired.

**Remark:** to reduce the risk of high frequency interference at lamp ignition, two capacitors have been added on the DC output.

## Component layout

### G3-80 / G3-100 models

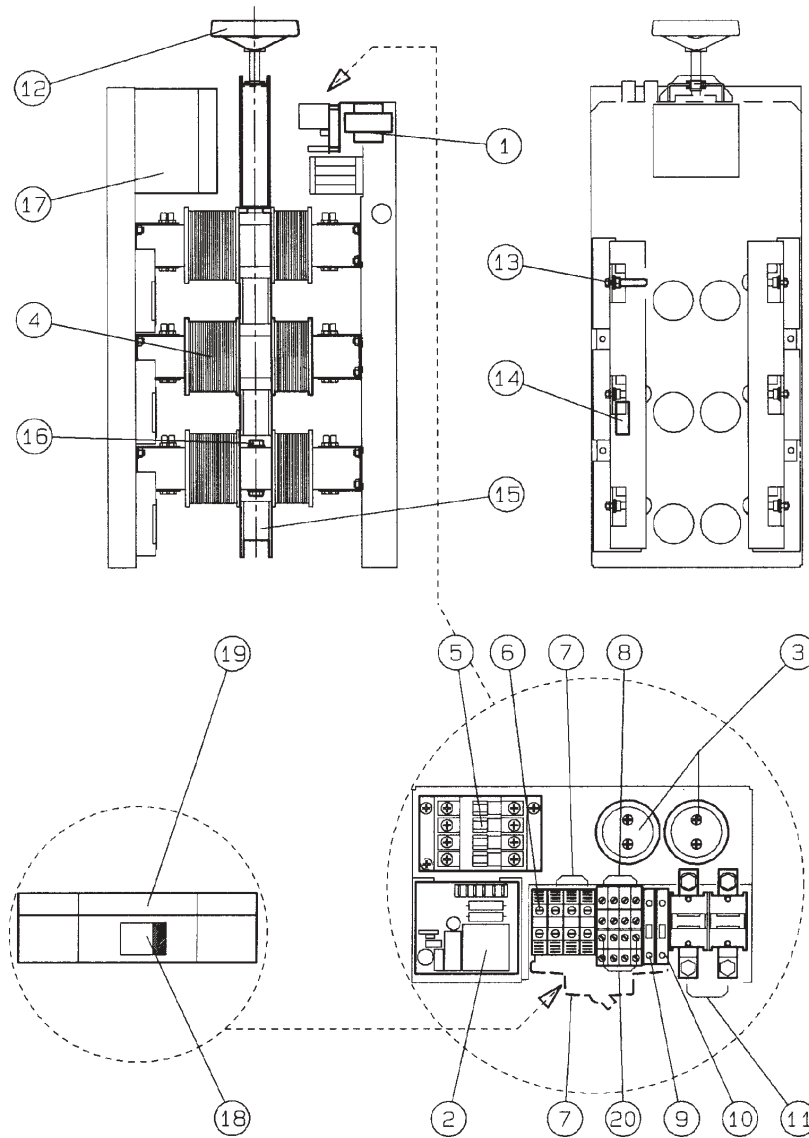

- |  |   |
|--|---|
| 1) Auxiliary autotransformer<br>(for input voltage exceeding 240Vac) | 11) Output terminals (+, -)                 |
| 2) Ignition relay (A1)   | 12) Adjustment hand-wheel                   |
| 3) Output filter capacitors (C7-C8)                                  | 13) Silicon diodes (D1 to D6)               |
| 4) Transformers (T1 to T3)   | 14) Protection capacitors (C1to C6)         |
| 5) Power relay (K1)  | 15) Magnetic shunt (MS)                     |
| 6) Ground terminal (PE)  | 16) Magnetic shunt adjustment               |
| 7) Input terminals (U, V, W)   | 17) Auxiliary filter (AFU) (L) (on request) |
| 8) Remote control and aux. outlet terminal board                     | 18) Circuit breaker (QF)*                   |
| 9) Fuse (F1)   | 19) Auxiliary contact (S1)*                 |
| 10) Fuse (F2)  | 20) Alarm ON/OFF terminal (X1)*             |
- \* with AFU only

**Component layout**

**G3-150 / G3-180 models**

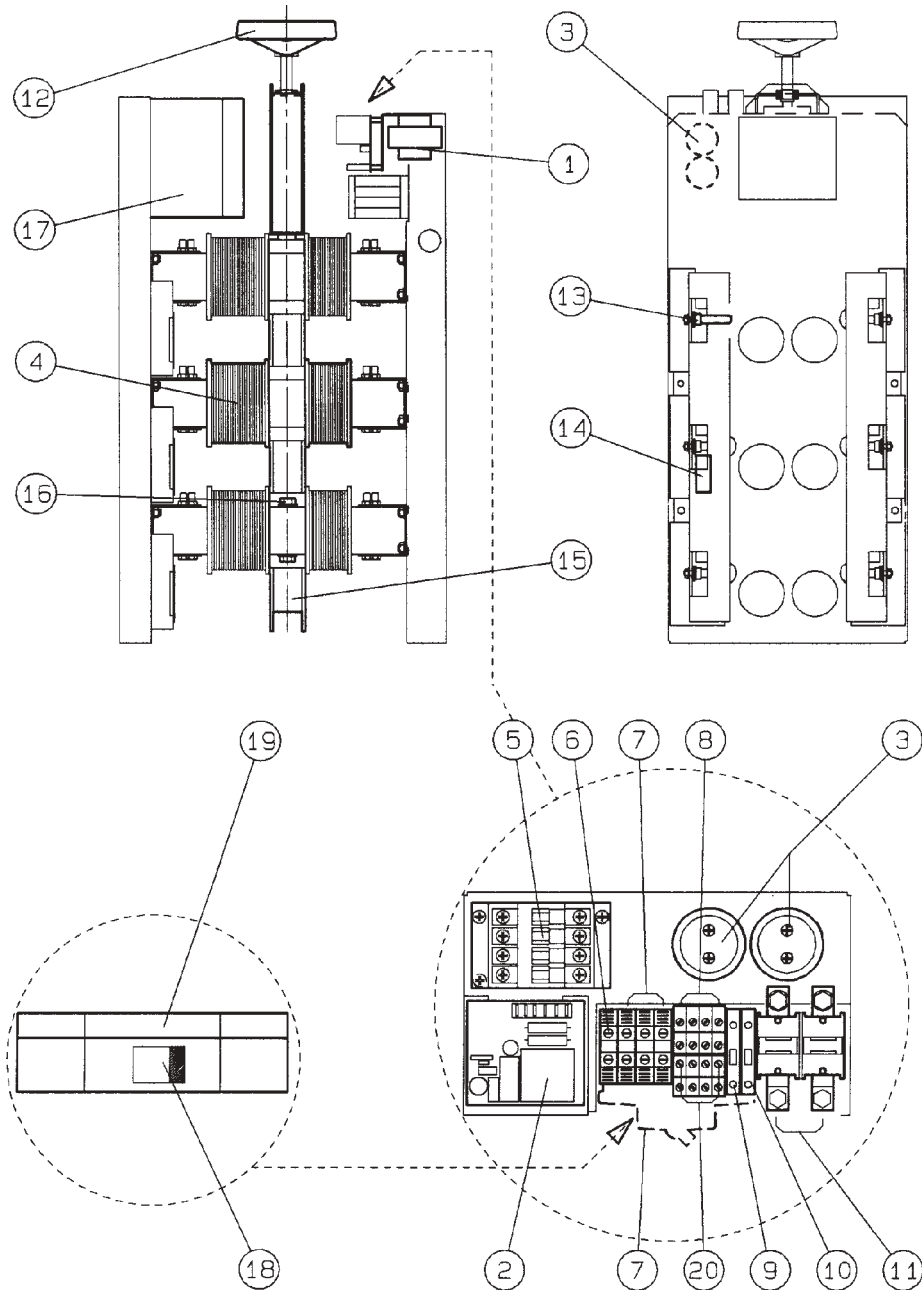

- |  |                                   |
|--|-----------------------------------|
| 1) Auxiliary autotransformer<br>(for input voltage exceeding 240Vac) | 11) Output terminals (+, -)       |
| 2) Ignition relay (A1)   | 12) Adjustment hand-wheel         |
| 3) Output filter capacitors (C7-C8)                                  | 13) Silicon diodes (D1÷D6)        |
| 4) Transformers (T1÷T3)  | 14) Protection capacitors (C1÷C6) |
| 5) Power relay (K1)  | 15) Magnetic shunt (MS)           |
| 6) Ground terminal (PE)  | 16) Magnetic shunt adjustment     |
| 7) Input terminals (U, V, W)   | 17) Auxiliary filter (AFU) (L)    |
| 8) Remote control and aux. outlet terminal board                     | 18) Circuit breaker (QF)          |
| 9) Fuse (F1)   | 19) Auxiliary contact (S1)        |
| 10) Fuse (F2)  | 20) Alarm ON/OFF terminal (X1)    |

## **Connection and operating information**

### **Receiving the equipment**

After receipt, check that the unit is in good condition. When necessary, contact the forwarding agent.

### **Delivery arrangement**

The supply consists of:  
**G3** rectifier power supply  
an installation and operation manual  
a warranty card.

### **Storage**

If the unit is stored before installation, check that it is kept dry and cannot come into contact with water in any form. Do not expose the unit to the sun rays or other sources of heat.

## Connection and operating information

### Package removing and handling

Remove the packing and keep it in case of future transportation needs.  
Avoid any shock when moving.

A dais with 3 anchoring bolts fixes the unit during transportation. To remove the dais, unscrew the bolt screws. When handling act on relevant lifting devices (see pictures below).

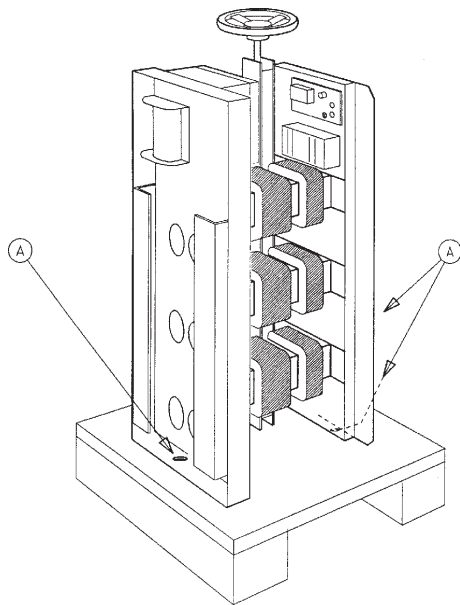

EYEBOLTS FOR HORIZONTAL LIFTING

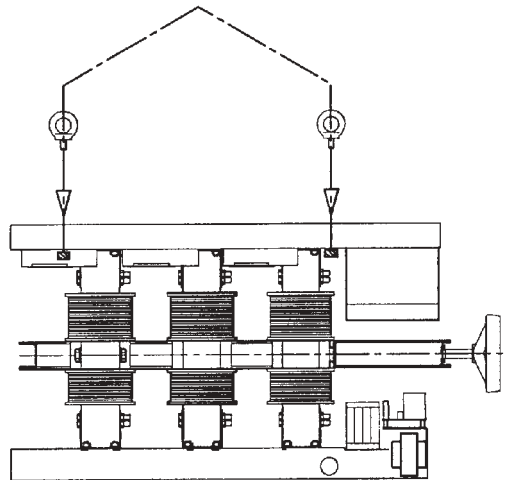

DEVICE FOR VERTICAL LIFTING  
(on request)

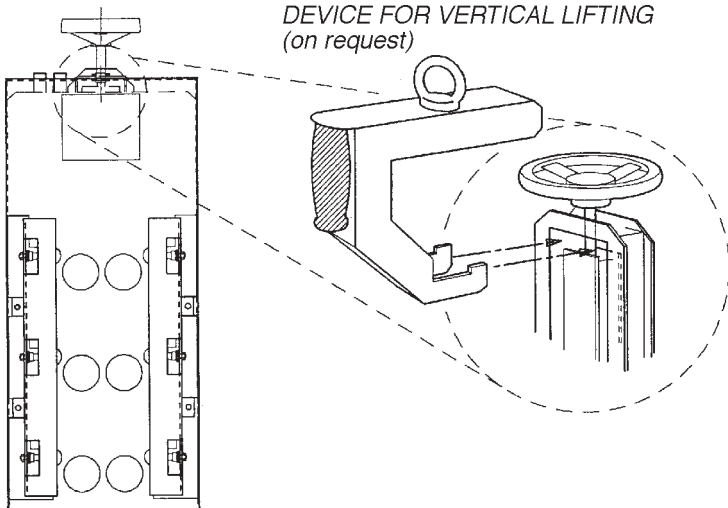

## **Connection and operating information**

### **Warnings**

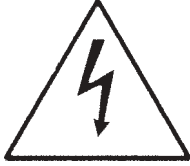

**Caution : dangerous voltage inside the rectifier power supply. Disconnect the unit from the mains before checking the internal components.**

**In case of failed ignition, wait 3 minutes at least for capacitor discharge.**

**Prevent water, liquids in general and/or foreign objects from getting inside the appliance (do not open the unit, contact IREM servicing centre !).**



**Check that a 100 mm (4 inch.) free space is left all around the unit to ensure the necessary ventilation and to prevent overheating.**

**To prevent blockages caused by overheating, do not expose the unit to the sun rays or other sources of heat.**

**Do not place anything on the upper side of the unit and ensure that the ventilation slots are unobstructed.**

**Installation must only be carried out by trained personnel.**

### **Preliminary checks**

**The connection must be carried out in compliance with the current safety standards. To ensure a correct operation of the unit, please strictly follow these recommendations:**

- the input powering has to be three phase and ground, withstanding current values as per unit dataplate
- the earth of the installation and the protections against indirect contacts must comply with current safety standards.

## **Connection and operating information**

### **Installation - use**

Connect the input and output lines to the "X1" terminal board, input terminals "U V W" (7), output terminals "+ and -" (11), by means of wires having a proper section (max. current density: 4A per sq/mm) and the ground wire to "PE" terminal (6).

To ensure a correct operation of the output terminals, please strictly follow this recommendation:

when tightening the connection bolt, we suggest that the cable is firmly held against the tightening force to prevent damage to the mounting rail and torque stresses being transferred to the terminal foot.

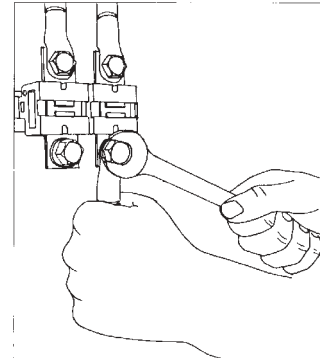

Connect the wires of the ON-OFF push button to the terminals marked "B, H, A" located on the terminal board (8).

On the same terminal board (8) and on the terminal with fuse "D" (9), there is also a 230V 2A outlet to power the igniter.

After connecting the unit, switch on the rectifier by means of the remote control switch.

When the lamp is on, adjust the current by means of the adjustment hand-wheel (12).

## Connection and operating information

### Installation - use

Rectifier power supplies equipped with auxiliary filter unit (AFU):

Check that the circuit breaker (18) protecting the ignition relay board is set to ON.  
If the circuit breaker is set to OFF, move to ON.

The circuit breaker tripping is remotely signalled through two contacts (19) connected to the alarm ON terminals (X1) - (20).

When the unit is properly operated and the circuit breaker (18) is set to ON the status of the contacts is:

contact on terminals F-G: open  
contact on terminals I-L: closed

If the circuit breaker trips, the status of the contacts is:

contact on terminals F-G: closed  
contact on terminals I-L: open

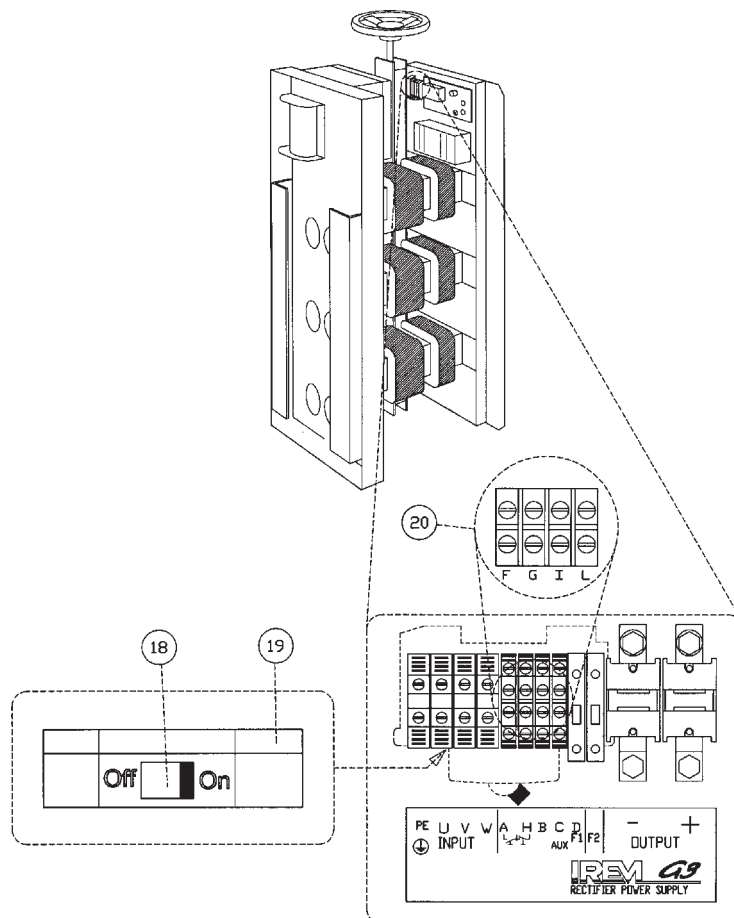

## Troubleshooting

### Possible failures



**Caution: dangerous voltage inside the rectifier power supply. Disconnect the unit from the mains before checking the internal components. Then wait 3 minutes at least for capacitor discharge.**

- A.** Operating the remote ON/OFF switch, the rectifier is not powered:
- 1) check the connection;
  - 2) check that the powering voltage is the proper one and that no phase is lacking;
  - 3) check the efficiency of K1 power relay; if damaged, replace it.
- B.** Operating the remote ON/OFF switch, the line protections blow:
- 1) check that there is no short circuit on the rectifier and, in particular, on the diodes "D1....D6", on the protection capacitors "C1....C6" of the rectifying heatsink and on "C7 or C8" capacitors.
- C.** The lamp does not ignite:
- 1) the lamp is damaged, replace it;
  - 2) there is no high voltage discharge into the lamp: check the proper operation of the igniter and verify that there is no discharge towards earth inside the lamphouse.
  - 3) if igniter and lamp are not damaged, check the efficiency of the rectifier: the no-load voltage must be 88-130V approx.  
If the no-load voltage is low:
    - check that the powering voltage is the proper one and that no phase is lacking;
    - check the efficiency of the diodes; if some of them are damaged, replace them following the instructions as per point no. B.1.
  - 4) be sure QF circuit breaker is set to ON (closed).
- D.** The output current has a too high ripple:
- 1) check that no phase is lacking;
  - 2) check the efficiency of the diodes; should they be damaged, replace them following the instructions as per point no. B.1;
  - 3) check the efficiency of "C7 or C8" capacitors: if damaged, replace them;
  - 4) check the efficiency of "A1" ignition relay : if damaged, replace it.
  - 5) be sure QF circuit breaker is set to ON (closed).

## **Troubleshooting**

- E. QF circuit breaker (protecting A1 board) trips. S1 contact closes down to warn the user. Check:
- 1) the presence of all the three input phases (U, V, W). Check the powering line upstream the rectifier and reset the lacking phase. Set QF circuit breaker to ON.
  - 2) the efficiency of the diodes (the diodes could be short circuited or interrupted). When necessary, replace the faulty diode (see relevant instructions on this manual). Set QF circuit breaker to ON.
  - 3) the efficiency of C7 and C8 capacitors. The capacitors could be short circuited (low Ohmic resistance between the terminals). When necessary, replace the faulty capacitor. Set QF circuit breaker to ON.
  - 4) the continuity of K1 power relay contacts. If there is no continuity, replace K1.
  - 5) the absence of overheating on the wiring joints to: primary and secondary coils, diodes, heat sinks and AFU filter.  
When necessary, reset the fault wiring joints. Set QF circuit breaker to ON.

## **Preventive maintenance**

Some components must be periodically replaced. This is due to their particular constructive featuring (like ageing). So, schedule a preventive maintenance and/or replacement on components listed below:

- electrolytic capacitors (C7-C8): schedule a replacement every 5 years
- D1 to D6 diodes: replace every 10 years.  
**Important note:** diode lockage must be performed by means of a dynamometric wrench (torque wrench setting: 3Nm) (26.8 lbf.in).
- K1 power relay: replace every 10 years.

## Troubleshooting

### Checking and replacing the diodes

The 6 diodes (in groups of 3) are mounted onto the two heat sinks placed on the top. Replace the damaged diodes as per picture and instructions below.

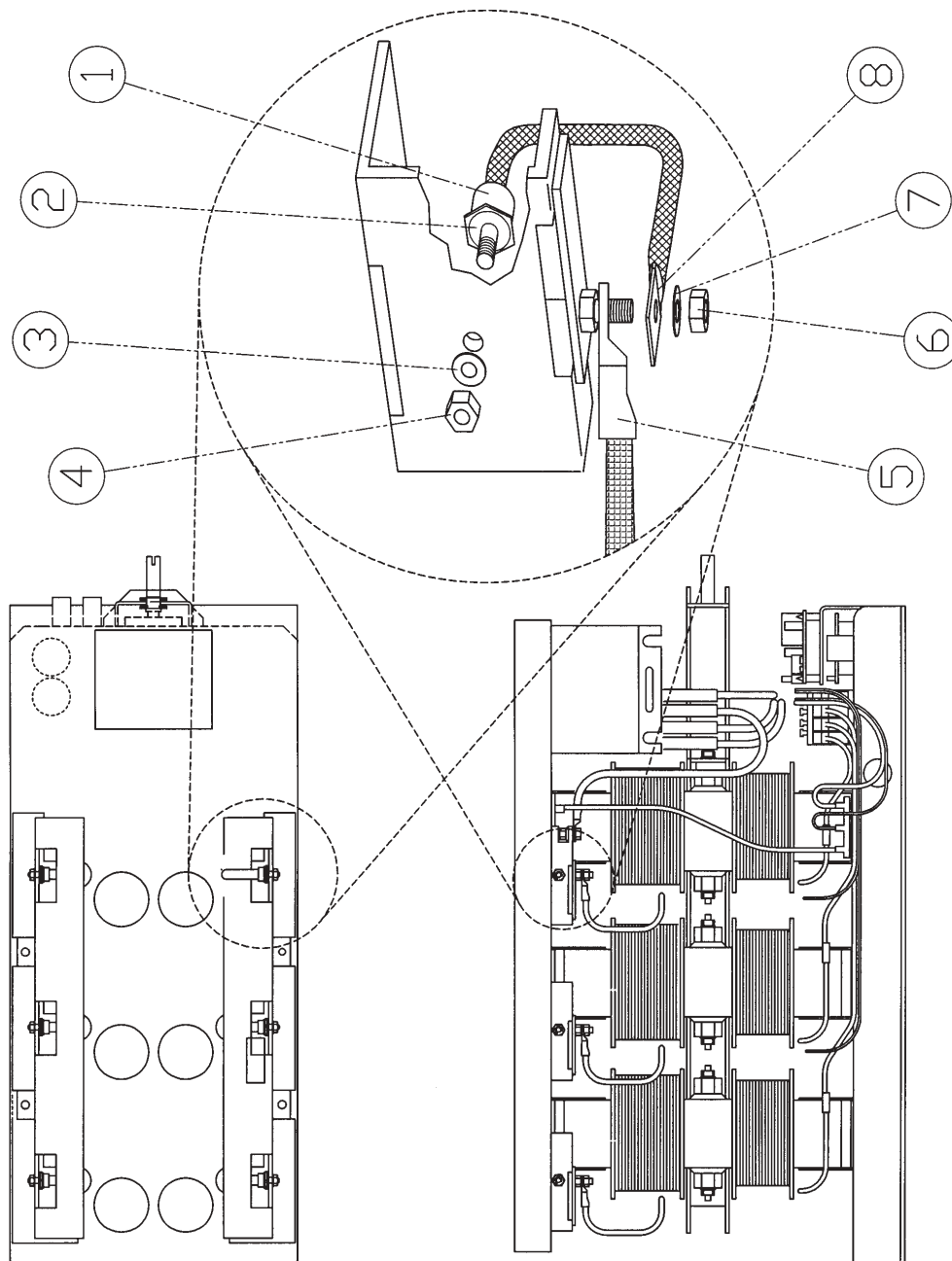

## Troubleshooting

- 1) Take off the M6 retaining nut (6) and the washer (7) by means of an hexagon wrench (10 mm/13/32"). Pull out the flexible end (tail) (8) from the screw terminal.
- 2) Set the multimeter (DVM) reading to the diode symbol.
- 3) Connect the red probe to one of the two heat sinks. Remark: usually, the red probe is the positive pole of the DVM battery, whilst the black one is the negative. The test diagram is shown below.

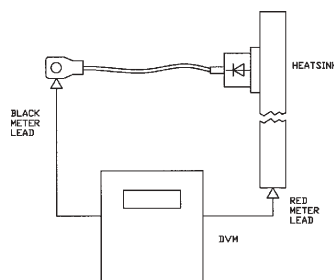

If the diode is OK, the reading range should be within 0.4 and 0.6  $\Omega$ . Reversing the probes will result in an infinite reading (out of scale).

If the diode is interrupted, the measurement will result in an infinite reading (out of scale).

If the diode is shorted (most common case) the DVM reads a value close to 0  $\Omega$ , even reversing the probes.

If the probes of DVM battery have reverse poles, the measurement will result in infinite reading. The reverse polarity has no effect on interrupted or shorted diodes.

- 4) The damaged diode should be then replaced as follows:
  1. lock the case (1) by means of an hexagonal wrench (17 mm type)
  2. by means of an hexagonal wrench (11 mm type ) completely rotate counter-clockwise the retaining nut (4) and the washer (3).

### Diode mounting directions

- a) spread some silicone compound onto the flat surface of the diode (2) (e.g.: Wacker silicone P12).
- b) insert the diode into the fixing hole . Lock the case (1) by means of a hexagonal wrench (17 mm type). Insert the spring washer (3) into the threaded tang and then rotate clockwise the retaining nut (4) by means of a dynamometric wrench (11 mm - 1/4") (wrenching torque: 3N·M (26.8 lbf.in).
- c) insert the diode end terminal (tail) (8) into the M6 retaining nut, and fix it by means of the washer (7) and the M6 nut (6).
- d) clamp the M6 nut (6) (dynamometric wrench: 10 mm - 13/32") (wrenching torque: 5N·M (45 lbf.in).

## Technical specifications

### Technical data

| Model  | DC output |         | Three phase input voltage range (V) | No-load voltage (V) | Max. drained power (kVA) | Drained current (A) | Current ripple with AFU* (%) | Current ripple without AFU* (%) | Efficiency |
|--------|-----------|---------|-------------------------------------|---------------------|--------------------------|---------------------|------------------------------|---------------------------------|------------|
|        | V         | A       |                                     |                     |                          |                     |                              |                                 |            |
| G3-80  | 21÷35     | 43÷85   | 190-220V - 50Hz                     | 115                 | 5.8                      | 16.8                | <3                           | <8                              | >0.8       |
|        |           |         | 208-230V - 60Hz                     | 116                 |                          | 15.2                |                              |                                 |            |
|        |           |         | 208-242V - 50Hz                     | 115                 |                          | 15.2                |                              |                                 |            |
|        |           |         | 380-440V - 50Hz                     | 118                 |                          | 8.4                 |                              |                                 |            |
|        |           |         | 394-456V - 50Hz                     | 118                 |                          | 8                   |                              |                                 |            |
| G3-100 | 28÷36     | 52÷110  | 190-220V - 50Hz                     | 115                 | 6.9                      | 21.5                | <3                           | <8                              | >0.8       |
|        |           |         | 208-230V - 60Hz                     | 116                 |                          | 18                  |                              |                                 |            |
|        |           |         | 208-242V - 50Hz                     | 116                 |                          | 18                  |                              |                                 |            |
|        |           |         | 380-440V - 50Hz                     | 120                 |                          | 10                  |                              |                                 |            |
|        |           |         | 394-456V - 50Hz                     | 120                 |                          | 9.6                 |                              |                                 |            |
| G3-150 | 28÷40     | 80÷150  | 190-220V - 50Hz                     | 116                 | 9.4                      | 27.5                | <3                           |                                 | >0.8       |
|        |           |         | 208-230V - 60Hz                     | 116                 |                          | 24.7                |                              |                                 |            |
|        |           |         | 208-242V - 50Hz                     | 116                 |                          | 24.7                |                              |                                 |            |
|        |           |         | 380-440V - 50Hz                     | 120                 |                          | 13.6                |                              |                                 |            |
|        |           |         | 394-456V - 50Hz                     | 116                 |                          | 13                  |                              |                                 |            |
| G3-180 | 28÷48     | 110÷165 | 190-220V - 50Hz                     | 128                 | 13                       | 37.5                | <3                           |                                 | >0.8       |
|        |           |         | 208-230V - 60Hz                     | 130                 |                          | 34                  |                              |                                 |            |
|        |           |         | 208-242V - 50Hz                     | 128                 |                          | 34                  |                              |                                 |            |
|        |           |         | 380-440V - 50Hz                     | 128                 |                          | 18.8                |                              |                                 |            |
|        |           |         | 394-456V - 50Hz                     | 128                 |                          | 18.1                |                              |                                 |            |

Marking:

CE, UL (for US market)

Operating temperature:

0°C to 40°C

Storage temperature:

-20°C to +60°C

Protection degree:

IP00

\* AFU: auxiliary filter unit

### Power factor correction

| Rectifier model | Input voltage (V)      | Reactive power (VAr) | Capacitor bank (µF) |
|-----------------|------------------------|----------------------|---------------------|
| G3-80           | 380-440 / 394-456 50Hz | 3000                 | 3x20                |
|                 | 208-230 - 60Hz         | 2800                 | 3x50                |
|                 | 208-242 - 50Hz         |                      | 3x60                |
|                 | 190-220V - 50Hz        | 3800                 | 3x80                |
| G3-100          | 380-440 / 394-456 50Hz | 4500                 | 3x30                |
|                 | 208-230 - 60Hz         | 4300                 | 3x80                |
|                 | 208-242 - 50Hz         |                      | 3x100               |
|                 | 190-220V - 50Hz        | 5500                 | 3x110               |
| G3-150          | 380-440 / 394-456 50Hz | 7500                 | 3x50                |
|                 | 208-230 - 60Hz         | 7300                 | 3x130               |
|                 | 208-242 - 50Hz         |                      | 3x150               |
|                 | 190-220V - 50Hz        | 7500                 | 3x120               |
| G3-180          | 380-440 / 394-456 50Hz | 8750                 | 3x60                |
|                 | 208-230 - 60Hz         | 8500                 | 3x155               |
|                 | 208-242 - 50Hz         |                      | 3x190               |
|                 | 190-220V - 50Hz        | 9500                 | 3x215               |

Capacitors are delta connected. They must be rated for the max. input voltage of the rectifier.

Capacitors have to be connected to the input terminals (U V W). For connection please refer to current safety standards.

MAN0100/3

**Outline drawing**

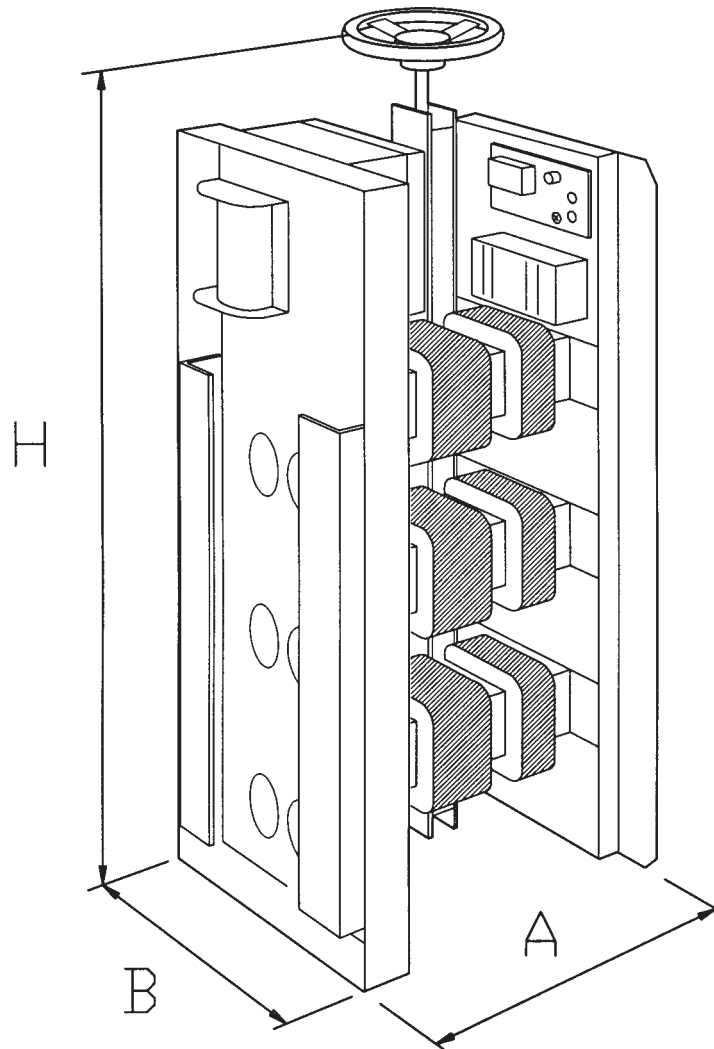

| Model  | Dimensions (mm)<br>(A x B x H) | Weight<br>(kg) |
|--------|--------------------------------|----------------|
| G3-80  | 410x301x785                    | 88             |
| G3-100 | 410x301x785                    | 108            |
| G3-150 | 410x301x785                    | 126            |
| G3-180 | 410x301x795                    | 154            |